

CEILING SPEAKER 6"

Borderless



With 40 Watts RMS 6" speaker

The Taramps 6" ceiling speaker was developed for residential and commercial environments and offers a more modern design with a fine finish. It is made of polypropylene material, with UV protection, to guarantee product quality for longer.

A practical and elegant solution to those who want high-quality sound at any environment without compromising space and aesthetics.



Suggestion for residential space



Gourmet space - Leisure area
Kitchens - Rooms in general and
other spaces...

Suggestion for commercial space



Bakeries - Supermarkets
Stores - Bars
Restaurants - Clinics
and other spaces...

Installation

The Taramps ceiling speaker was designed to be easy to install with no complications.

Follow the instructions below to obtain satisfactory results:

- 1- With the product out of the packaging, take the cardboard cutout template to make the correct marking on the plasterboard or where you will embed it.
- 2- Remove the front screen, using a thin, sharp object. Be careful not to damage the plastic parts (Use a utility knife or screwdriver carefully).
- 3- Connect the wires to the Borne terminal (Red = positive and Black = negative).
- 4- Check that the 4 fixing latches are positioned inwards. If not, position them.
- 5- Fit the ceiling speaker into the location to be fixed and, using a screwdriver or Philips screwdriver, tighten the screws proportionally and slowly until you notice that the ceiling speaker is firm. When tightening, the latches will rotate automatically to lock position.
- 6- Once this is done, check if it is fitted correctly and place the front screen.
- 7- That's it, your ceiling speaker has been successfully installed.

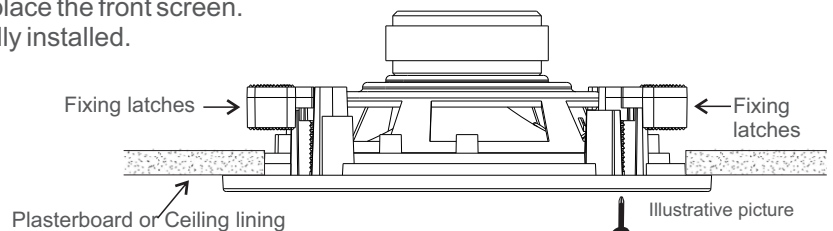

CAUTION When using an electrical screwdriver, make sure the torque is not high. Excessive torque could cause complications for your installation and the product.

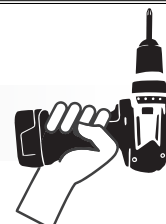

CEILING SPEAKER 6" Borderless



With 40 Watts RMS 6" speaker

Technical characteristics

RMS POWER	40 WATTS
PROGRAM POWER	80 WATTS
NOMINAL IMPEDANCE	4 Ohms or 8 Ohms
FREQUENCY RESPONSE	40Hz to 18.000Hz
RESONANCE FREQUENCY	56,911 Hz
WEIGHT	1.65lb (0,75Kg)

Access the product on our website:



Product dimensions

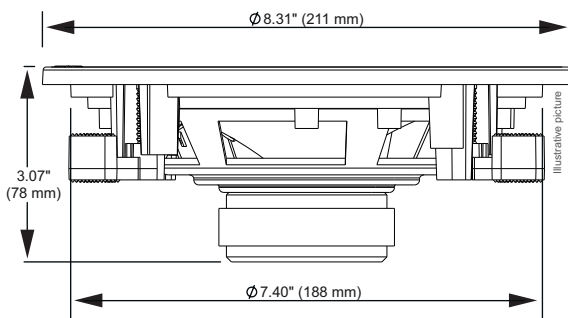

For installation, use the cardboard cutout template that comes with the product. Minimum ceiling cutout size Ø7.874" (Ø200mm).

Installation suggestion

1x Taramps THS 6000 + 4x Taramps 4 Ohm Ceiling Speakers + 1x 200 Watts RMS Passive Subwoofer

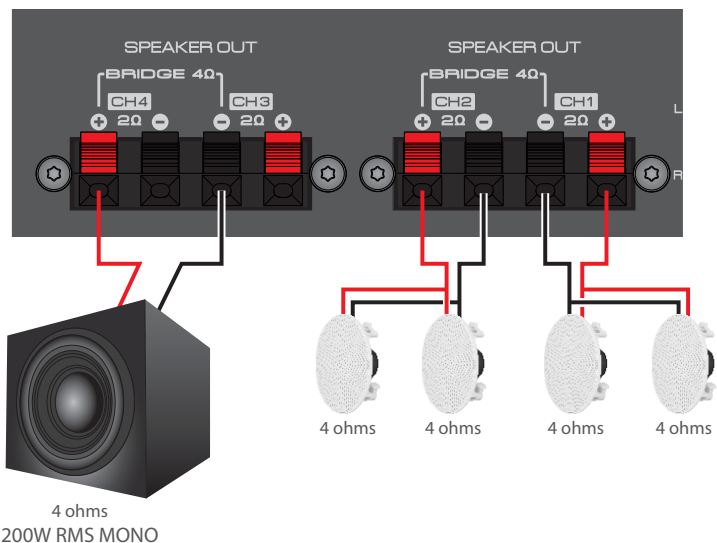

NOTE: Characteristics, specifications, and aesthetic aspects are subject to change without prior notice.

WARRANTY TERM

When all our products are produced, they undergo rigorous evaluations, in each construction process until they are packaged, however, if any type of abnormality is detected, when opening the package, it must be sent to one of our authorized service stations, or directly to the factory, if there is not an authorized technician in your region. **Each and every product must undergo a technical evaluation so that the defect is identified and proven.**

The product has a warranty of 15 (fifteen) months after the issuance of the invoice, with the legal warranty of 90 days, provided for in article 26, item II, of law No. 8078/90 (Brazilian consumer protection code).

Warranty Conditions:

The product must be installed correctly, by a specialized professional, as well as respecting the product characteristics.

The customer **will NOT** have the warranty when:

- Exceed the period of 15 (fifteen) months.
- Damages incurred are caused by; transport or handling accident, or humidity.
- Defects caused by improper installation.
- Malfunctions in product parts (torn cone/dust cap, bent or broken speaker housing).
- Coils burned out by excessive power or extreme distortion conditions, causing heating above 240°.

Warranty Coverage:

- Taramps guarantees its products against any defect in material or manufacturing process, provided that, at the discretion of its authorized technicians, it is found to be defective under normal conditions of use.
- **The PRODUCT must contain the original label, on which its serial number is inserted.**
- To use the warranty, the customer must present the invoice and the warranty term, both of which must contain the serial number on the product label.

Transport

Only products that fall under the terms of warranty coverage will have their transportation expenses covered, otherwise, the expense will be at the customer's expense.

WARRANTY CERTIFICATE

NAME: _____

ADDRESS: _____

CITY: _____ ZIP: _____

STATE: _____ PHONE: _____

DEALER: _____

ADDRESS: _____

CITY: _____ ZIP: _____

STATE: _____ PHONE: _____

INVOICE NUMBER